

QUANTITY	MATERIAL	DESCRIPTION
8	FRP	1/4" THK. X 2'-0" W X 1'-10" DP X 20'-11" TROUGH "A"
24	STEEL	1 1/2 X 1 1/2 X 1/4" THK. X 18'-11 5/8" LG EMBEDDED STEEL
4	FRP	1/4" THK. X 2'-0" W X 1'-10" DP X 17'-7" TROUGH "B"
12	STEEL	1 1/2 X 1 1/2 X 1/4" THK. X 15'-7 11/16" LG EMBEDDED STEEL
112	PVC	Ø1 1/2" X 2'-0" LG SPREADER BAR (1/2-13 TAP BOTH ENDS)
12	FRP	3/8" THK. X 2'-8 3/4" W X 2'-1 1/4" H SADDLE
64	FRP	3 X 3 X 1/4" THK. X 2" LG CLIP ANGLE
8	FRP	2" SQ. X 1/4" THK. X 2'-10 3/4" LG STABILIZER "A"
8	FRP	2" SQ. X 1/4" THK. X 5'-10 1/2" LG STABILIZER "B"
96	304 SS	Ø1/2 X 3 3/4" EXPANSION ANCHORS
220	304 SS	Ø1/2 X 1 1/2" HHMB
328	304 SS	Ø1/2 FLAT WASHER
108	304 SS	Ø1/2 HEX NUTS
16	304 SS	Ø3/8 X 3 3/4" EXPANSION ANCHORS
32	304 SS	Ø3/8 X 3 1/2" HHMB
48	304 SS	Ø3/8 X 1 1/2" HHMB
160	304 SS	Ø3/8 FLAT WASHER
80	304 SS	Ø3/8 HEX NUTS
1	N/A	RESIN KIT

NOTE:  
ALL DIMENSIONS ARE IN INCHES.

**PROPPRIETARY AND CONFIDENTIAL**  
 THE INFORMATION CONTAINED IN THIS DRAWING IS THE SOLE PROPERTY OF NATIONAL WATER TREATMENT PRODUCTS. ANY REPRODUCTION IN PART OR AS A WHOLE WITHOUT THE WRITTEN PERMISSION OF NWTP IS PROHIBITED.

SHEET NO.	DIVISION: NWTP
	DRAWN BY: x
1	CHECKED BY:
	APPROVED BY:
	DATE: x

**NATIONAL**  
WATER TREATMENT PRODUCTS

SCALE: TITLE: Trough Wall Assembly REF:

NO.	REVISIONS	DATE

NATIONAL WATER TREATMENT PRODUCTS has no responsibility for the contract design of the product or the contract specifications. NWTP has been selected to manufacture this product, the customer agrees to indemnify and hold NWTP harmless from and against all merchantability and fitness for purpose (including all liability for claims, suits, judgements and expenses), unless the product as manufactured by NWTP does not conform to the contract design and specifications set or NWTP's shop drawings approved by the customer.

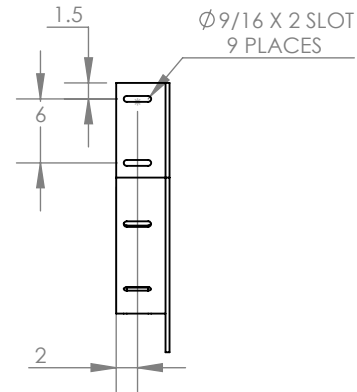
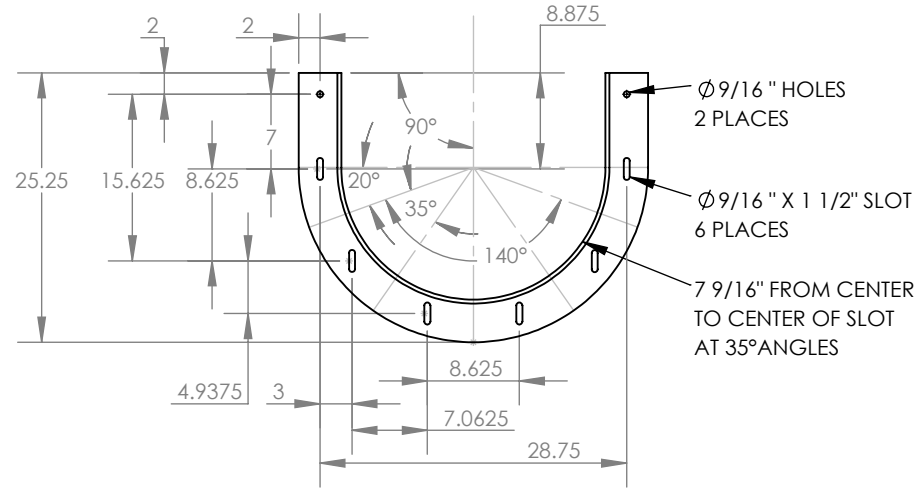
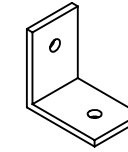
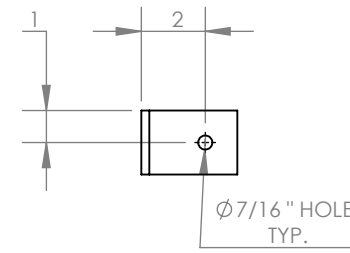
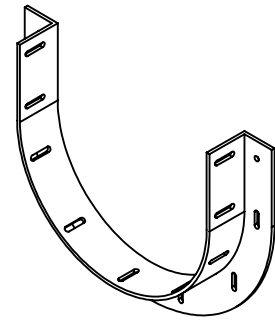
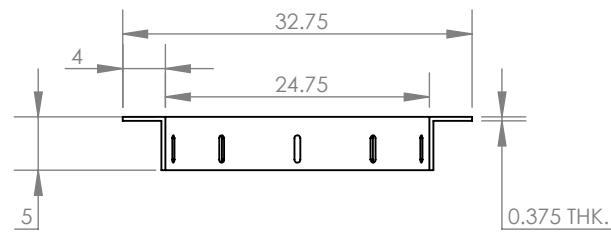

3 X 3 X 1/4\"/>

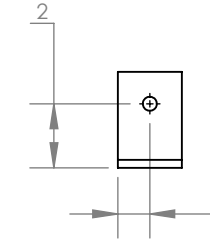
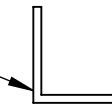

**CLIP ANGLE**

**SADDLE**

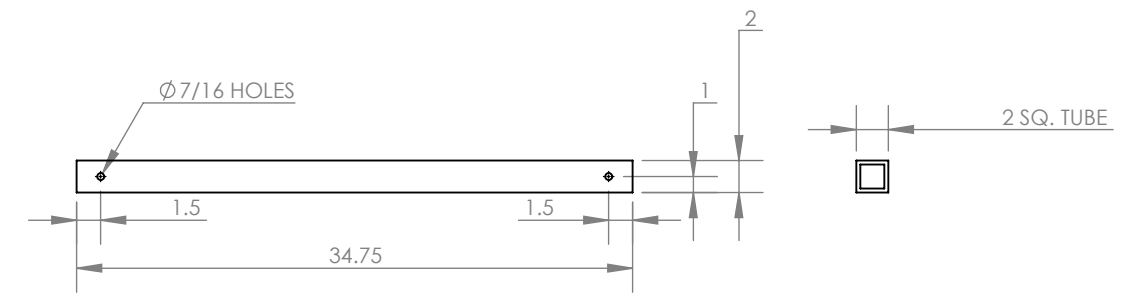

**STABILIZER A**

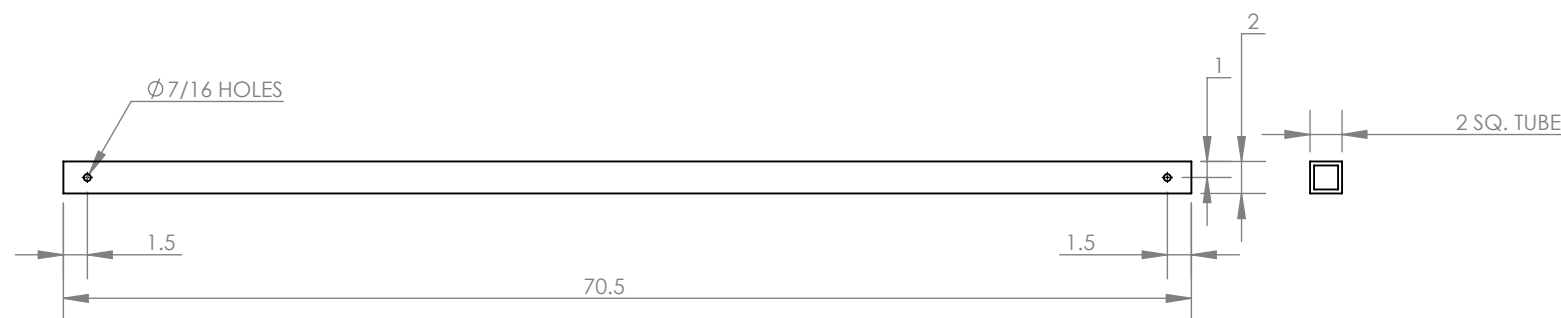

**STABILIZER B**

NOTE:  
ALL DIMENSIONS ARE IN INCHES.

**PROPRIETARY AND CONFIDENTIAL**  
THE INFORMATION CONTAINED IN THIS DRAWING IS THE SOLE PROPERTY OF NATIONAL WATER TREATMENT PRODUCTS. ANY REPRODUCTION IN PART OR AS A WHOLE WITHOUT THE WRITTEN PERMISSION OF NWTP IS PROHIBITED.

SHEET NO.	DIVISION: NWTP
	DRAWN BY: x
2	CHECKED BY:
	APPROVED BY:
	DATE: x



**NATIONAL**  
WATER TREATMENT PRODUCTS

SCALE:	TITLE: Trough Wall Assembly	REF:
--------	--------------------------------	------

NO.	REVISIONS	DATE

NATIONAL WATER TREATMENT PRODUCTS has no responsibility for the contract design of the product or the contract specifications. NWTP has been selected to manufacture this product, the customer agrees to indemnify and hold NWTP harmless from and against all merchantability and fitness for purpose (including all liability for claims, suits, judgements and expenses), unless the product as manufactured by NWTP does not conform to the contract design and specifications set or NWTP's shop drawings approved by the customer.

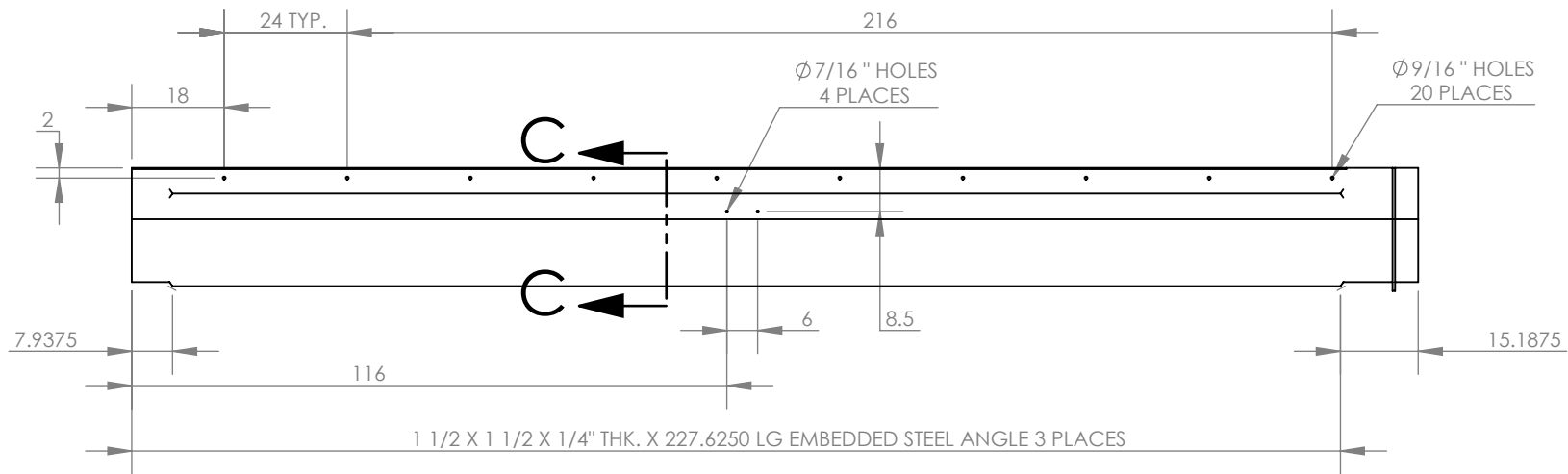
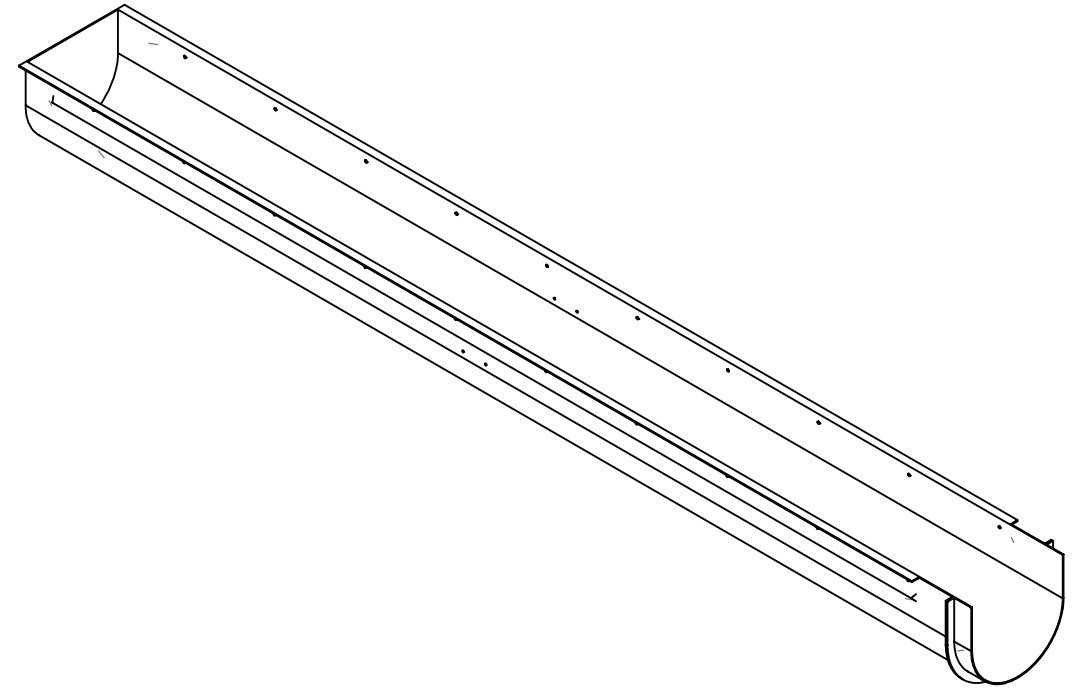
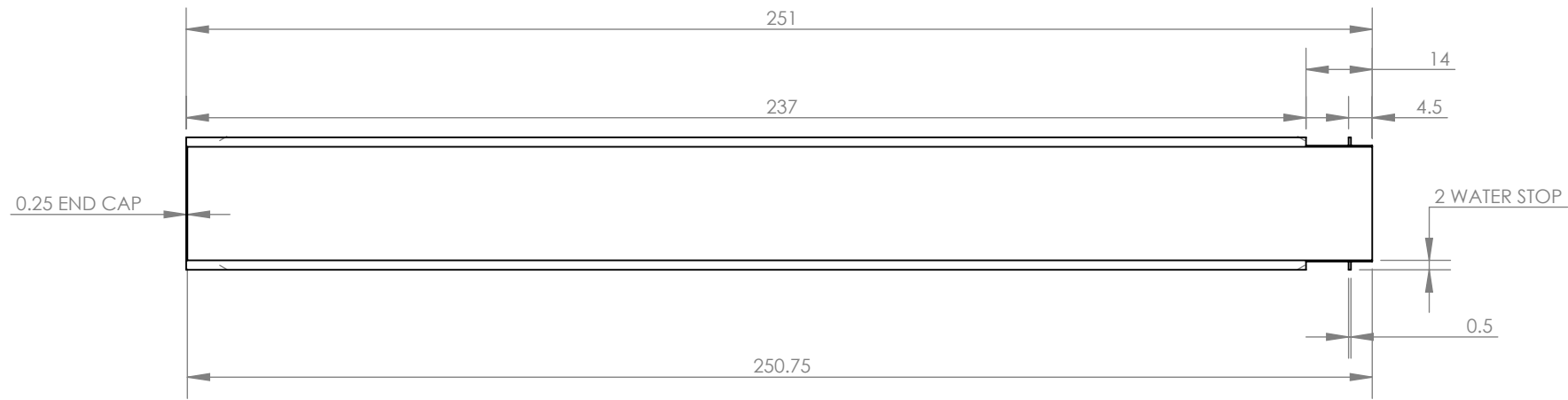

TROUGH A

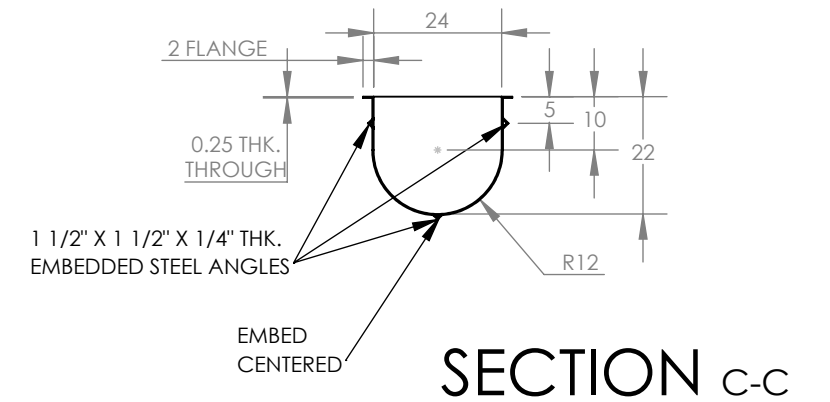
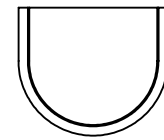

NOTE:  
ALL DIMENSIONS ARE IN INCHES.

**PROPRIETARY AND CONFIDENTIAL**  
THE INFORMATION CONTAINED IN THIS DRAWING IS THE SOLE PROPERTY OF NATIONAL WATER TREATMENT PRODUCTS. ANY REPRODUCTION IN PART OR AS A WHOLE WITHOUT THE WRITTEN PERMISSION OF NWTP IS PROHIBITED.

SHEET NO.	DIVISION: NWTP		NO.	REVISIONS	DATE	NATIONAL WATER TREATMENT PRODUCTS has no responsibility for the contract design of the product or the contract specifications. NWTP has been selected to manufacture this product, the customer agrees to indemnify and hold NWTP harmless from and against all merchantability and fitness for purpose (including all liability for claims, suits, judgements and expenses), unless the product as manufactured by NWTP does not conform to the contract design and specifications set or NWTP's shop drawings approved by the customer.	
	DRAWN BY: x						
3	CHECKED BY:		SCALE:	TITLE: Trough Wall Assembly	REF:		
	APPROVED BY:						
	DATE: x						

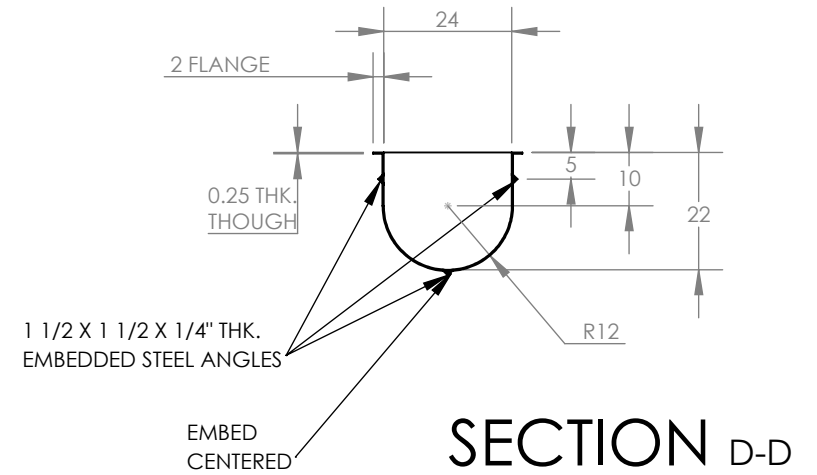
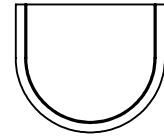
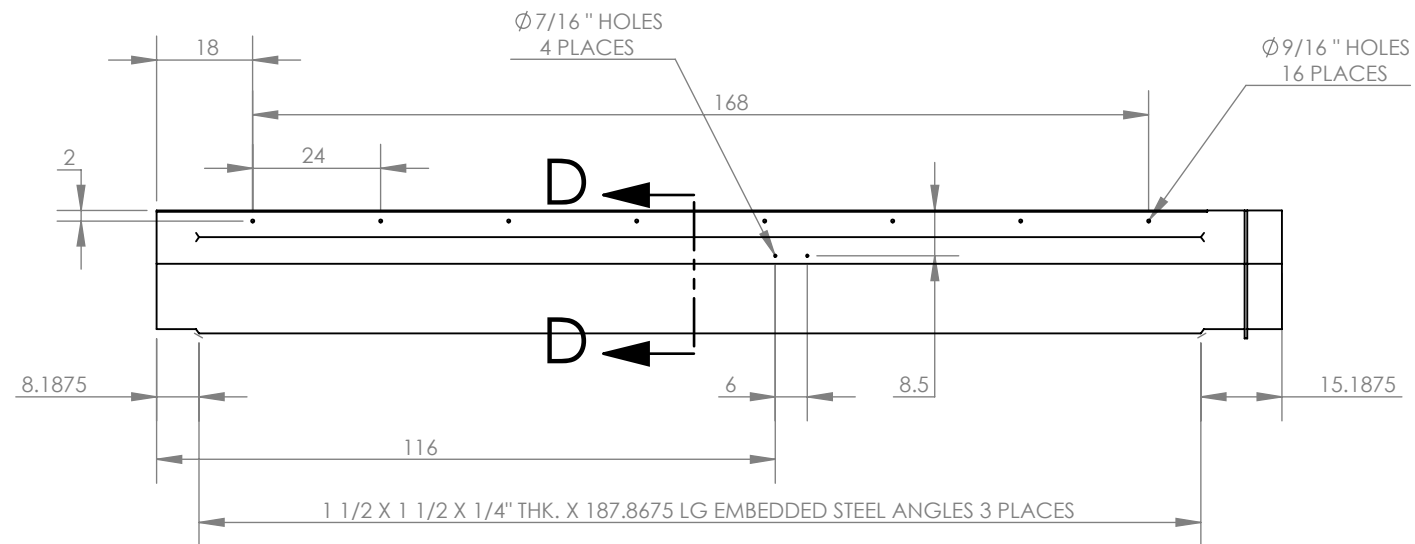
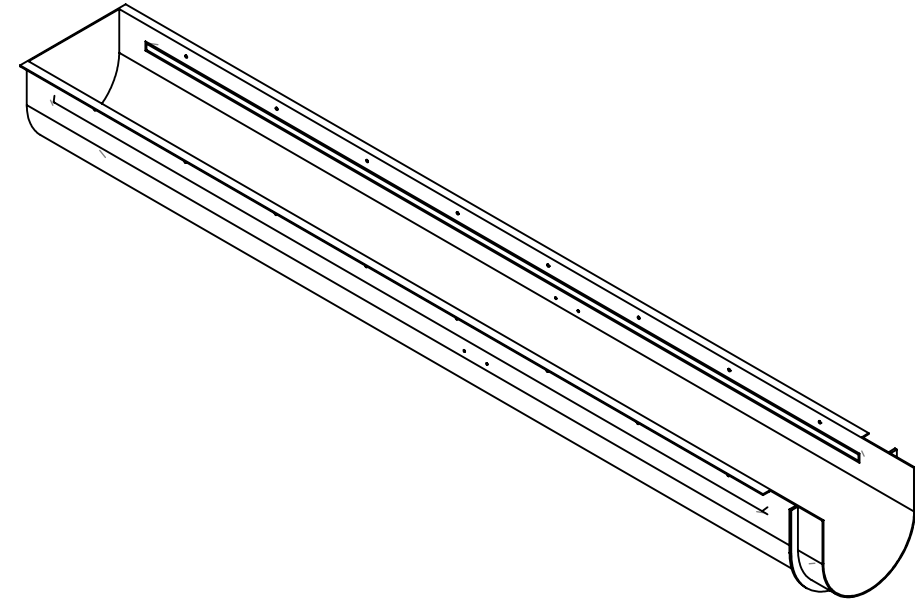
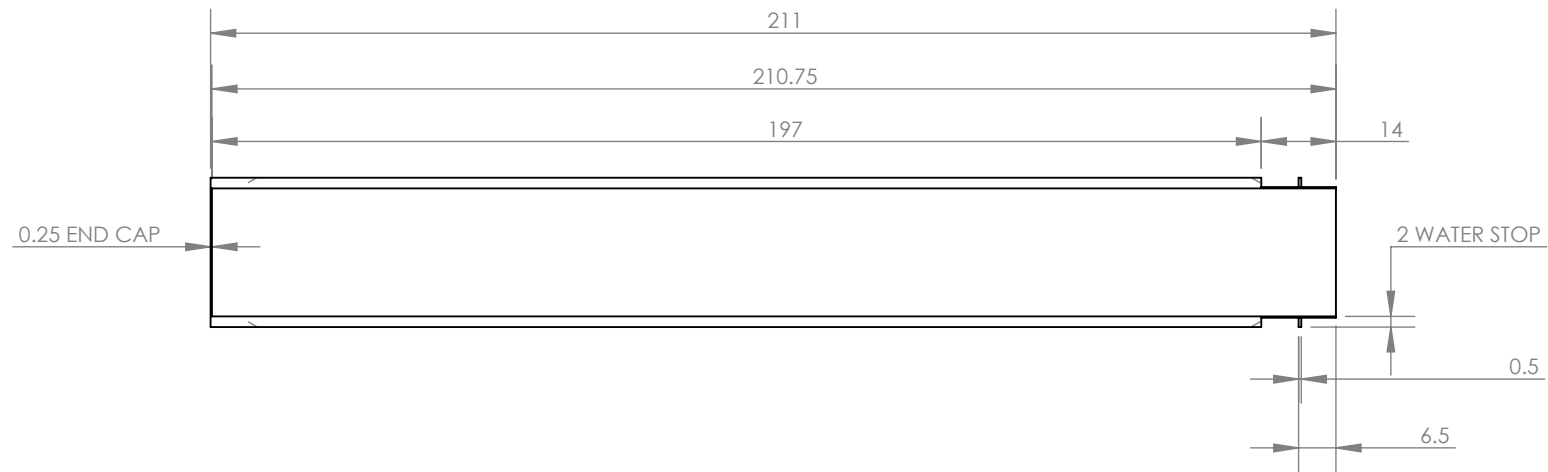

TROUGH B

NOTE:  
ALL DIMENSIONS ARE IN INCHES.

**PROPRIETARY AND CONFIDENTIAL**  
THE INFORMATION CONTAINED IN THIS DRAWING IS THE SOLE PROPERTY OF NATIONAL WATER TREATMENT PRODUCTS. ANY REPRODUCTION IN PART OR AS A WHOLE WITHOUT THE WRITTEN PERMISSION OF NWTP IS PROHIBITED.

SHEET NO.	DIVISION: NWTP		NO.	REVISIONS	DATE	<p>NATIONAL WATER TREATMENT PRODUCTS has no responsibility for the contract design of the product or the contract specifications. NWTP has been selected to manufacture this product, the customer agrees to indemnify and hold NWTP harmless from and against all merchantability and fitness for purpose (including all liability for claims, suits, judgements and expenses), unless the product as manufactured by NWTP does not conform to the contract design and specifications set or NWTP's shop drawings approved by the customer.</p>	
	DRAWN BY: x						
4	CHECKED BY:						
	APPROVED BY:						
	DATE: x		SCALE:	TITLE: Trough Wall Assembly	REF:		