

NOTE:
ALL DIMENSIONS ARE IN INCHES.

PROPRIETARY AND CONFIDENTIAL
THE INFORMATION CONTAINED IN THIS DRAWING IS THE SOLE PROPERTY OF NATIONAL WATER TREATMENT PRODUCTS. ANY REPRODUCTION IN PART OR AS A WHOLE WITHOUT THE WRITTEN PERMISSION OF NWTP IS PROHIBITED.

SHEET NO. 1	DIVISION: NWTP
	DRAWN BY: x
	CHECKED BY:
	APPROVED BY:
DATE: x	

NATIONAL
WATER TREATMENT PRODUCTS

SCALE:

TITLE: Square Laundry Cover Typical

REF:

NO.	REVISIONS	DATE

NATIONAL WATER TREATMENT PRODUCTS has no responsibility for the contract design of the product or the contract specifications. NWTP has been selected to manufacture this product, the customer agrees to indemnify and hold NWTP harmless from and against all merchantability and fitness for purpose (including all liability for claims, suits, judgements and expenses), unless the product as manufactured by NWTP does not conform to the contract design and specifications set or NWTP's shop drawings approved by the customer.

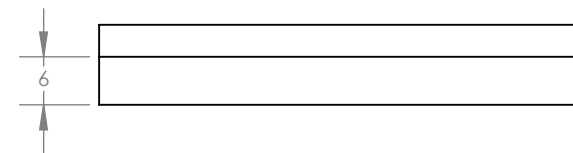
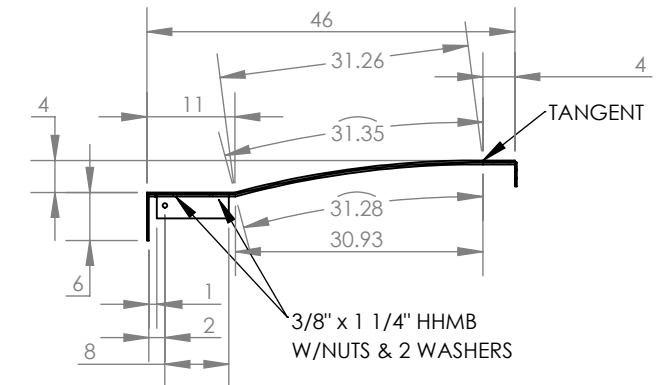
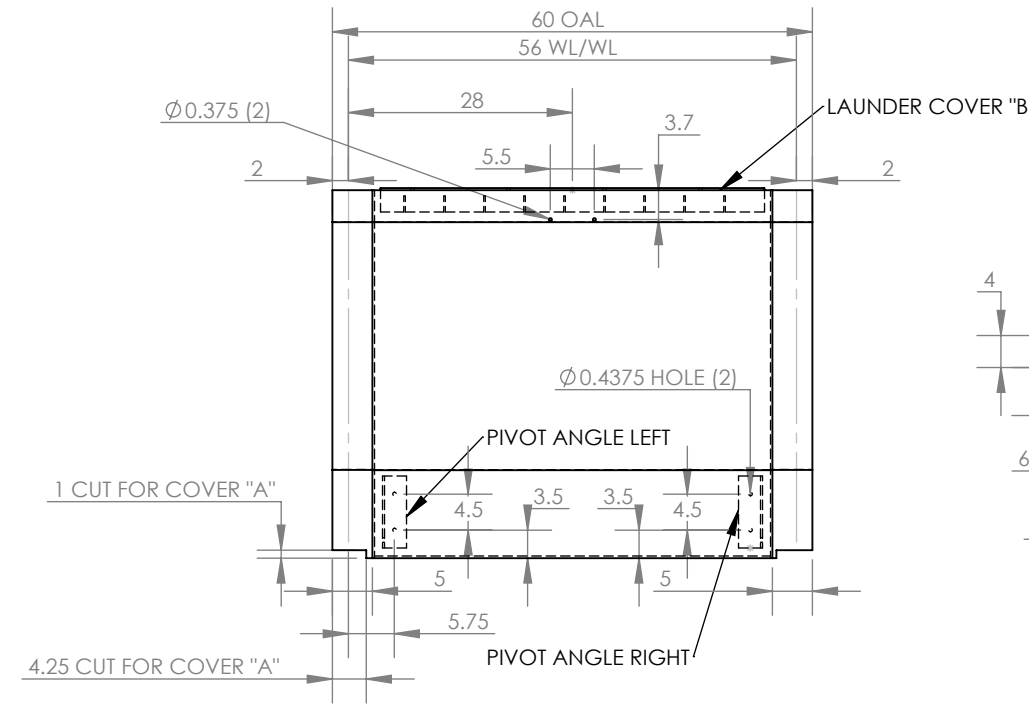
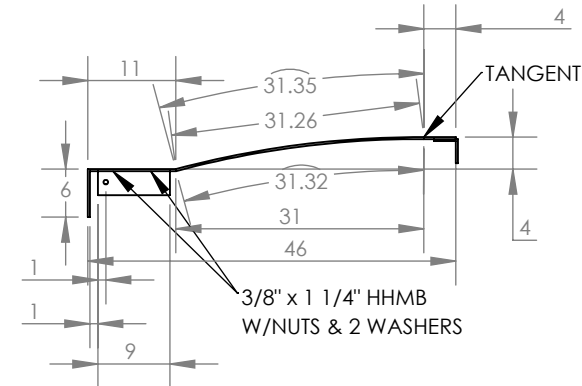
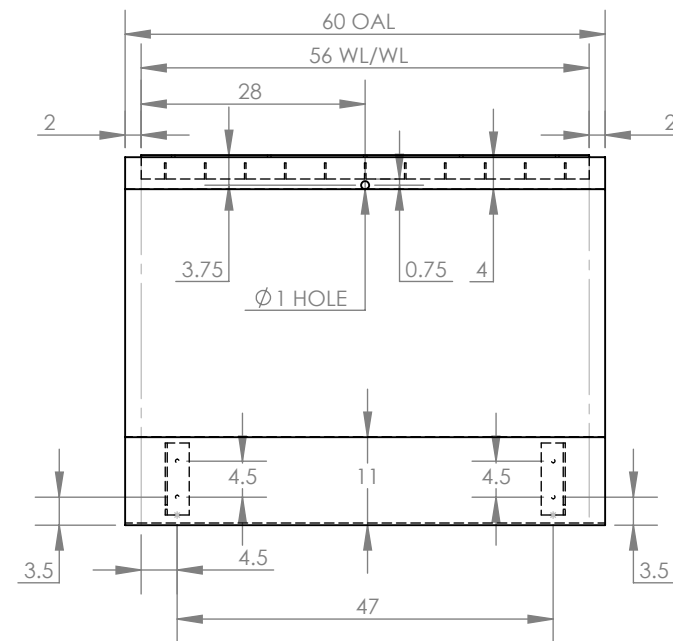

Laundry Cover "A"

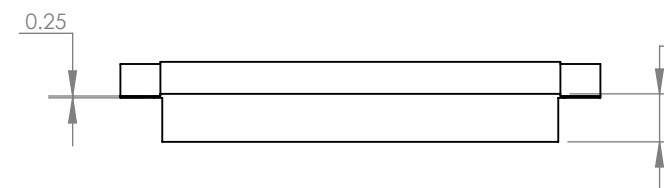

Laundry Cover "B"

NOTE:
ALL DIMENSIONS ARE IN INCHES.

PROPRIETARY AND CONFIDENTIAL
THE INFORMATION CONTAINED IN THIS DRAWING IS THE SOLE PROPERTY OF NATIONAL WATER TREATMENT PRODUCTS. ANY REPRODUCTION IN PART OR AS A WHOLE WITHOUT THE WRITTEN PERMISSION OF NWTP IS PROHIBITED.

SHEET NO.	DIVISION: NWTP
	DRAWN BY: x
2	CHECKED BY:
	APPROVED BY:
	DATE: x



SCALE: TITLE: Square Laundry Cover Typical REF:

NO.	REVISIONS	DATE

NATIONAL WATER TREATMENT PRODUCTS has no responsibility for the contract design of the product or the contract specifications. NWTP has been selected to manufacture this product, the customer agrees to indemnify and hold NWTP harmless from and against all merchantability and fitness for purpose (including all liability for claims, suits, judgements and expenses), unless the product as manufactured by NWTP does not conform to the contract design and specifications set or NWTP's shop drawings approved by the customer.

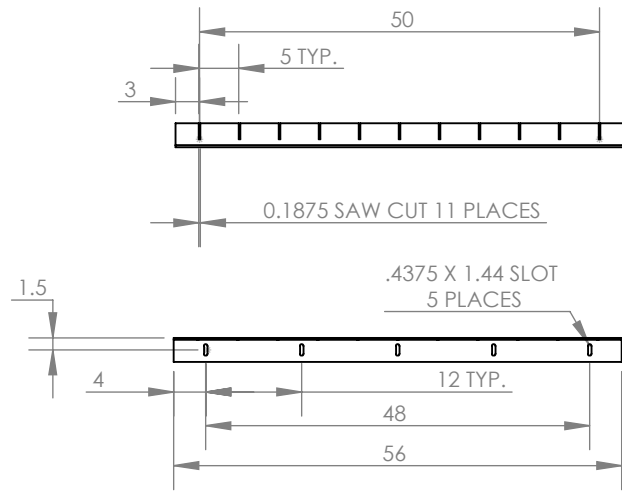

WALL ANGLE

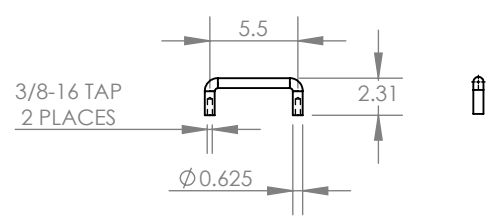
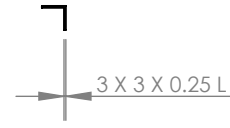

S.S. HANDLE

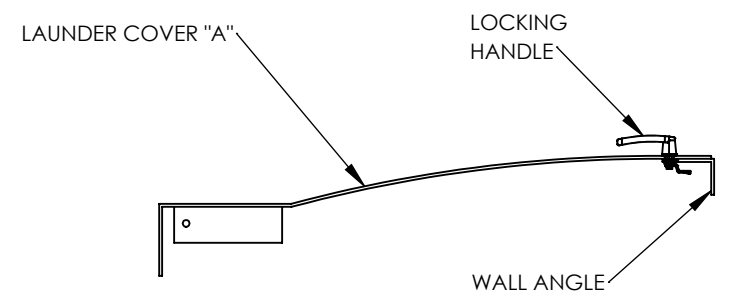

LOCKING HANDLE PLACEMENT

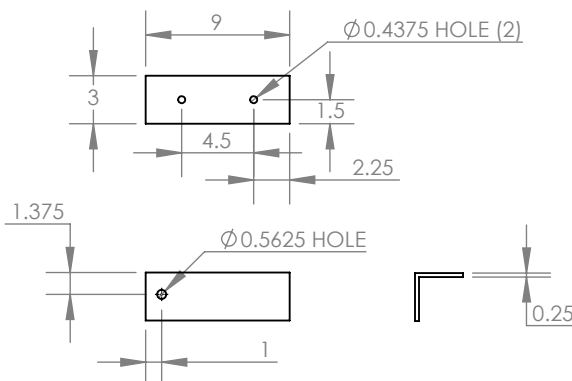

3 X 3 X .25 FRP PIVOT ANGLE RIGHT

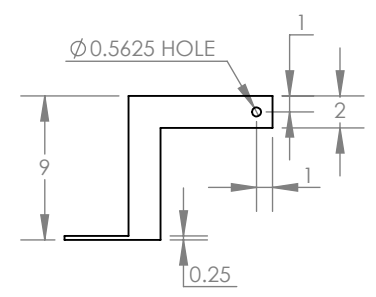

316 S.S. PIVOT ASSEMBLY

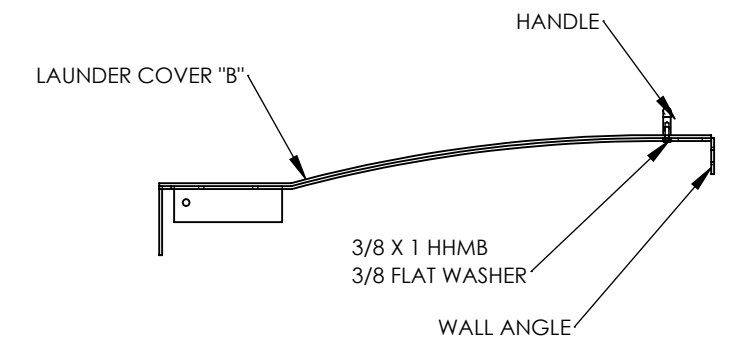

S.S. HANDLE PLACEMENT

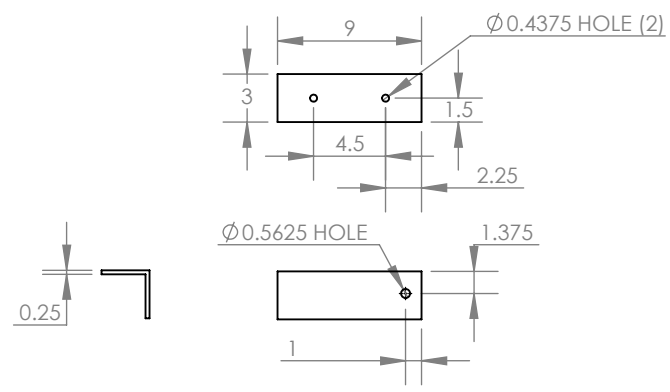

3 X 3 X .25 FRP PIVOT ANGLE LEFT

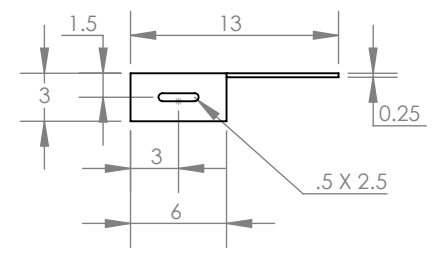

NOTE:
ALL DIMENSIONS ARE IN INCHES.

PROPRIETARY AND CONFIDENTIAL
THE INFORMATION CONTAINED IN THIS DRAWING IS THE SOLE PROPERTY OF NATIONAL WATER TREATMENT PRODUCTS. ANY REPRODUCTION IN PART OR AS A WHOLE WITHOUT THE WRITTEN PERMISSION OF NWTP IS PROHIBITED.

SHEET NO.	DIVISION: NWTP		NO.	REVISIONS	DATE	<p>NATIONAL WATER TREATMENT PRODUCTS has no responsibility for the contract design of the product or the contract specifications. NWTP has been selected to manufacture this product, the customer agrees to indemnify and hold NWTP harmless from and against all merchantability and fitness for purpose (including all liability for claims, suits, judgements and expenses), unless the product as manufactured by NWTP does not conform to the contract design and specifications set or NWTP's shop drawings approved by the customer.</p>
	DRAWN BY: x					
CHECKED BY:						
APPROVED BY:						
DATE: x						
3	SCALE:	TITLE: Square Launer Cover Typical	REF:			